

Operative Technique

RETRON Humeral Head Nail

RETRON)



RETRON Humeral Head Nail System

The number and complexity of humeral head fractures increase with advancing age. A definite increase in incidents due to demographic changes can be expected. As a result of growing demands on physical activities, the tendency in favour of operative treatment for humeral head fractures will be observed.

The RETRON nail is suited to this development, given that, alternative procedures of treatment due to long physical-therapeutic follow-up treatment with only gradual improvement of the mobility, the patient's claim to untimely physical activity is partially unjust.

An implant system for this indication should include the possibility of:

- Prevention of the humeral head
- Minor invasive Operative procedure
- Protection of the subacromial region

The goal of treatment with the RETRON system is the stabilisation and conservation of the bone structure. Entry of the RETRON nail occurs laterally transdermal, underneath the onset of the Delta muscle. The joint is not opened.

The anchorage of the fragments is carried out with the cannulated screws, which are angle and slip stable though the implantation of the RETRON nail. This principle of intramedullary force conduction and cannulated screws creates good stabilisation of the fragments and reduces secondary dislocations.

This system is suitable for subcapital and pertubercular humeral fractures.

The RETRON system offers young patients with good bone quality splendid support of the fracture. Protection of the subacromial region through lateral entry underneath the onset of the Delta muscle is an important prerequisite for good rehabilitation results especially with young patients.

For the treatment of older patients with increasing osteoporosis, the demand for anchoring the implant in the humeral head is escalated.

The subchondral region of the bone is used for a reliable fixation of the RETRON nail. The nail is guided in just to the cartilage and generates a good condition for a stable osteosynthesis due to its proximal thread.

An additional advantage of the RETRON system is the complete preservation with all types of retraction.

All in all, the RETRON system complies with the accustomed tantum principle: The system is an innovative product, of the best quality, to economic conditions.

))) Features and benefits at a glance

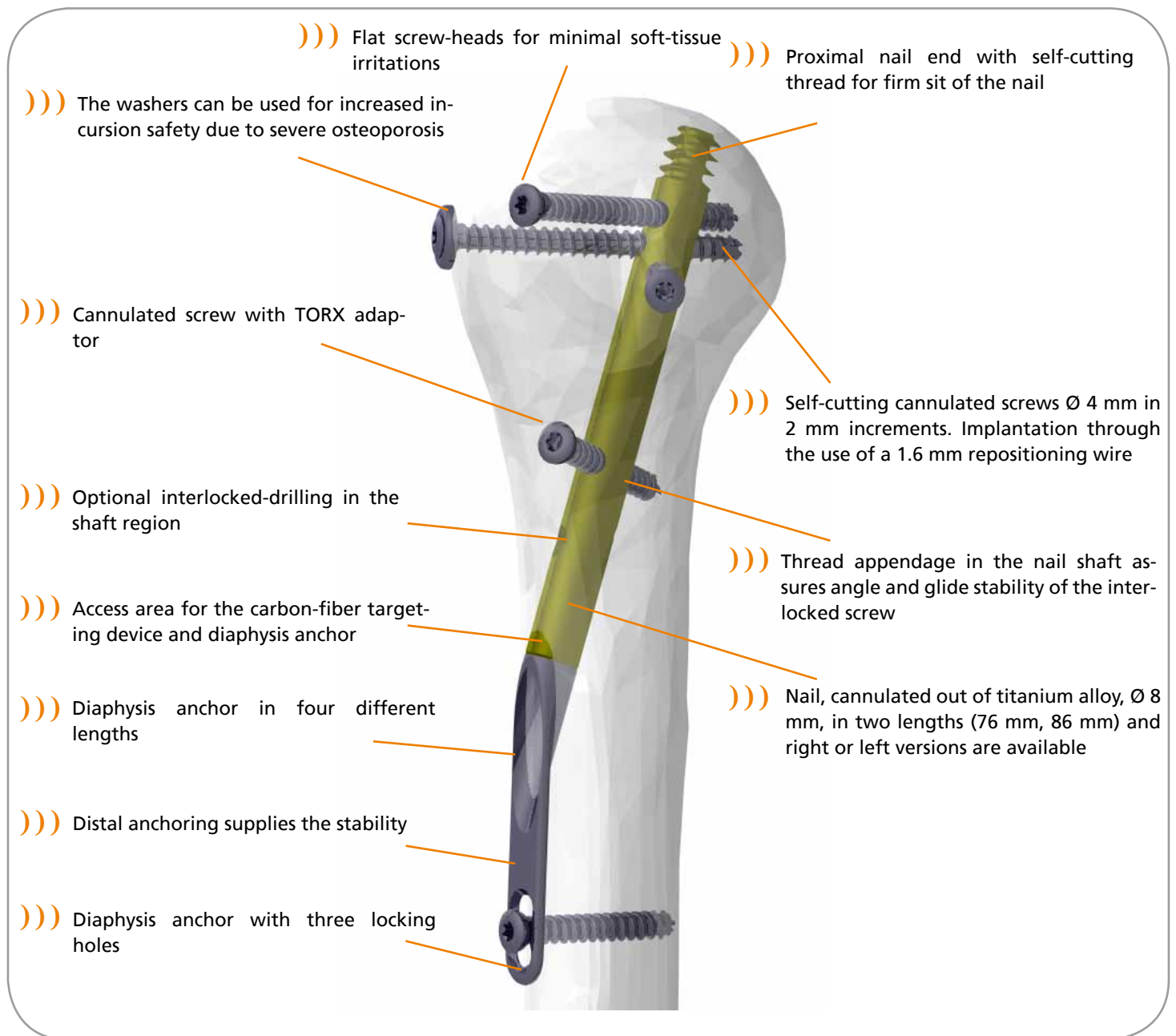

(tantum)))
the medical people

Operative technique

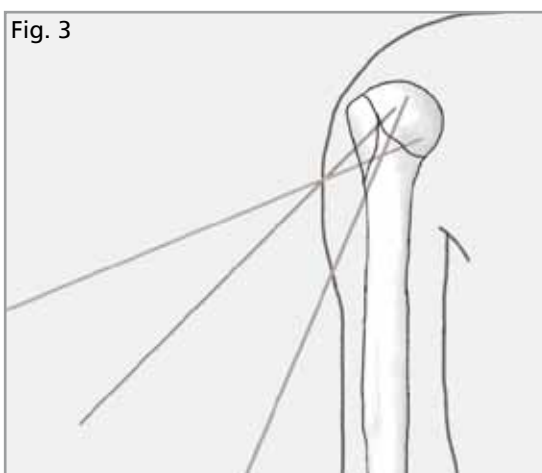
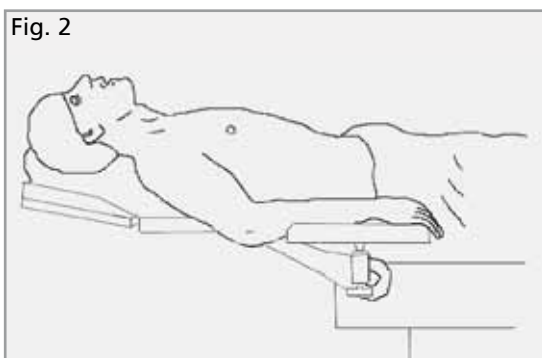
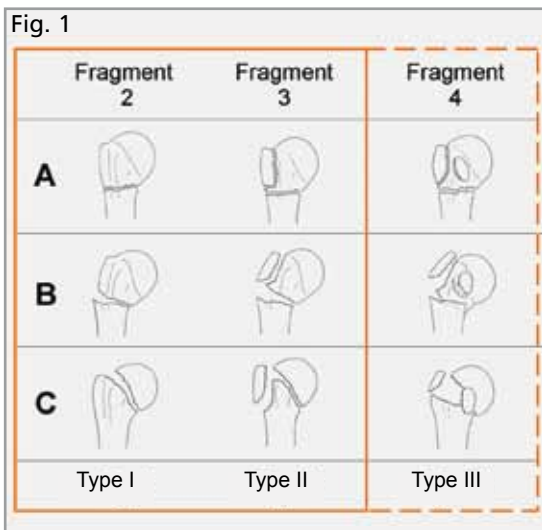

1. Indication

Subcapital and pertubercullary multiple fragment fractures of the humeral head up to Habermeyer type II, in individual cases up to type III.

2. Positioning of the Patient

Position the patient in a dorsal position on the shoulder table. The arm should be placed in a freely moveable position (Fig. 2). The C-arm should be positioned towards the head in the direct axis of the table.

3. Reposition of the Fragments

An x-ray in two levels (a-p and axis level) is required for reduction of the fragments. On the basis of the fracture type, the number of fragments, as well as their correlated position to each other can draw conclusions to the soft tissue anastomosen between the fragments (periosteum and sinews) and the required reduction technology.

CT-3D-Reconstructions using the percutaneous method, at least initially are for a complete compilation of the fracture very helpful.

The goal of the reduction is the restoration of the slide mechanism in the subacromial cavity. In other words, the tubercle and the articular fragment are brought into the anatomic position and temporarily fixated with K-wires. The fixation can remain until the introduction of the implant, as long as the wires are not in the way (Fig. 3). The reduction can alternatively be held by the assistant with an oval awl.

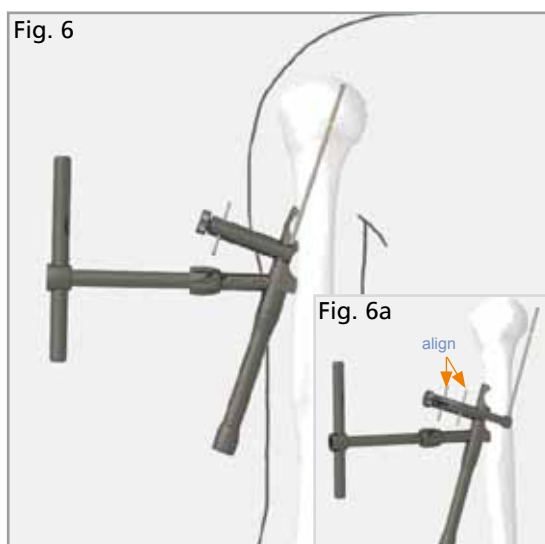
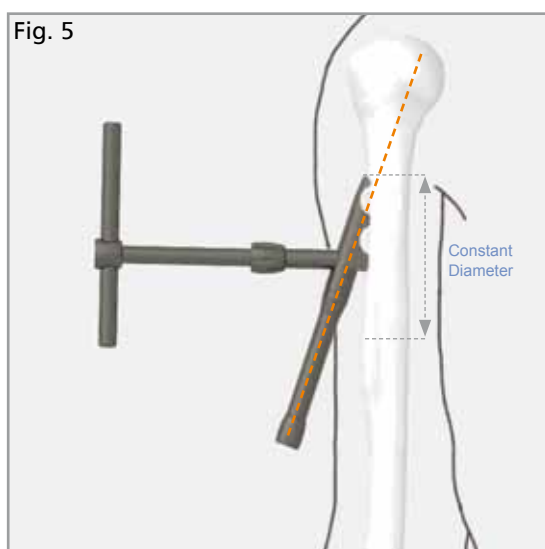
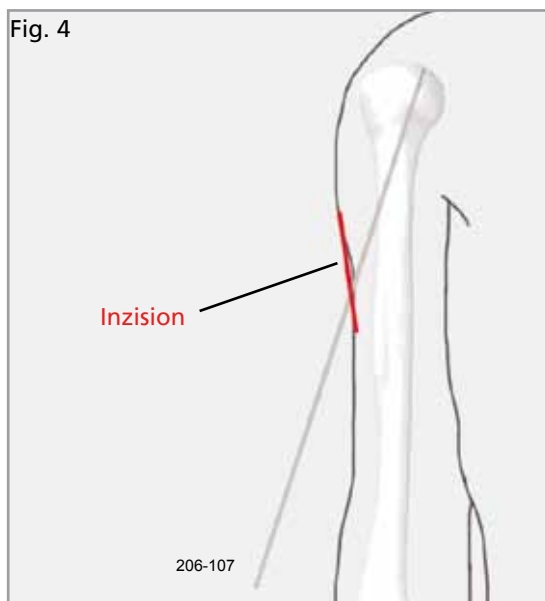

4. Entry and opening

For localization of the entry-point angle the arm in a light outward rotational position, so that the greater tuberosity is prominently depicted.

The guide wire (Cat no. 206-107) is then placed on the upper arm and is positioned in the designated direction and under fluoroscopy aligned in the intended direction of the nail.

The planned incision can then be marked on the skin using a pen (Fig. 4).

Particular attention should be placed on the axillary nerve while entering using the puncture incision and blunt preparation.

5. Affixing the RETRON Positioning Guide

The RETRON Positioning Guide (Cat no. 204-115) is assembled next.

Screw the positioning guide (Cat no. 204-115A) and the base together, as well as the positioning guide sleeve.

The RETRON Positioning Guide is directed percutaneously to the cortex.

Attention: Note the location of the axillary nerve. Place the positioning guide severely lateral on the onset of the greater tubercle crest. The longitudinal alignment positions itself due to the concave contact surface. Position it so that the proximal end stands upright, where the humeral shaft begins to nearly show a constant cross-section (Fig. 5).

6. Aligning the RETRON Positioning Guide

The attachment for positioning guide (Cat no. 204-116) can optionally be used to identify the ideal point for the positioning guide. The short indicator (Cat no. 204-116A, yellow colour-coded) is then assembled to the attachment for this purpose. The attachment is screwed onto the positioning guide and inserted onto the bone. Align the unit in the a-p path of rays under X-ray control (Fig. 6a). The positioning guide is optimally in the path of rays, when the two pins of the attachment are aligned.

The height of the positioning guide should be selected so that the end of the indicator is subchondral in the middle third of the humeral head. If necessary exchange indicator L76 for indicator L86 (Cat no. 204-116B).

Operative Technique

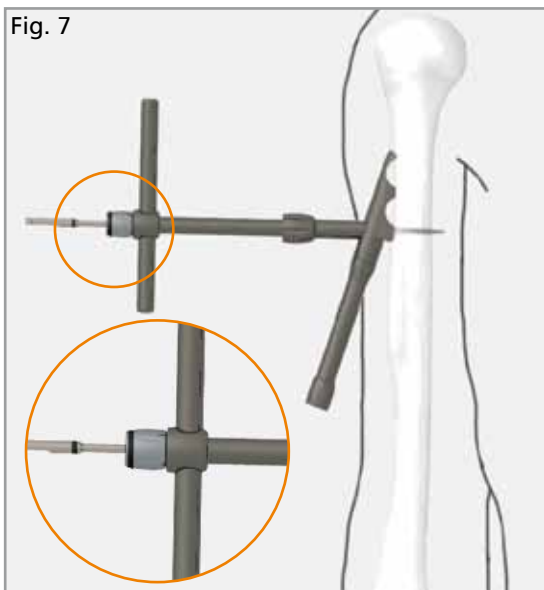

7. Fixation of RETRON Positioning Guide

Fixation of the positioning guide with the fixing screw for positioning guide (Cat no. 204-142). For this purpose insert the guide sleeve (Cat no. 202-130 black ring marking) into the positioning guide and using the drill (Cat no. 203-142), drill bicortically (Fig. 7).

The fixation screw is temporarily affixed and later exchanged with a cannulated screw, therefore only a 30mm length is required.

Remove the guide sleeve and screw in the fixing screw (Cat no. 204-142) with the cannulated screwdriver (Cat no. 201-146). Screw the fixing screw into the bone until the positioning guide is set firmly onto the bone (Fig. 8).

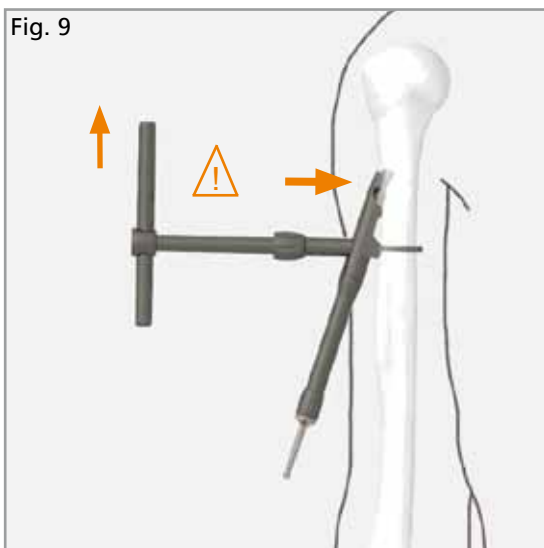

8. Bone preparation

To prevent the wire guide from straying, the bone should be prepared with the spot facer $\varnothing 8$ (Cat no. 203-139). The spot facer should then be guided through the sleeve (Cat no. 204-115c) of the positioning guide using a high rotational until completely inserted.

Note: When opening the lateral cortex with the spot facer, it is important to lightly press the proximal portion of the positioning guide, so that the drilling is not cranially diverted (Fig. 9).

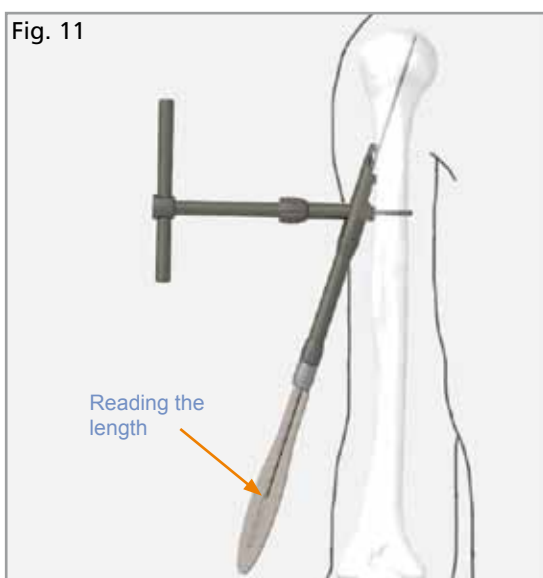
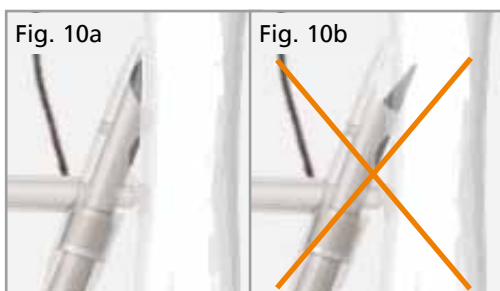
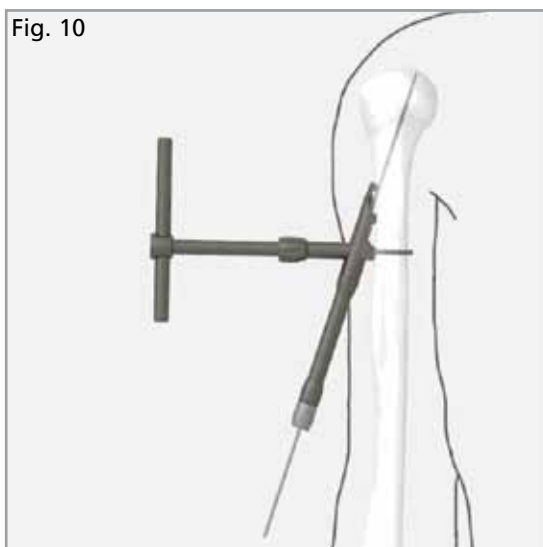

9. Insertion of the Nail Guide Wire

The guide sleeve $\varnothing 8 / \varnothing 2.5$ (Cat no. 202-129) is pushed through the positioning guide to the cortex. The nail guide wire $\varnothing 2.5 / L 300$ (Cat no. 206-107) is inserted into the humeral head through the guide sleeve using a drill. The wire ends at the middle third of the humeral head and in the subchondral region (Fig. 10).

The tip of the tissue protection sleeve is bevelled on one side. It is imperative that attention is paid to the alignment of the sleeve on the bone (Fig. 10a and Fig. 10b).

Depending on the adjustment of the image intensifier during X-ray, occasional projection errors may occur. A safety distance between the tip of the nail guide wire and the calotte must be kept in order to avoid drilling through the humeral head.

Note: A soft pressing of the proximal part of the positioning guide is advisable when introducing the nail guide wire.

10. Length measuring

Calculate the drill depth with the RETRON length gauge initially (Cat no. 208-106).

Note: To determine the length correctly, the nail guide wire is placed subchondrally, the guide sleeve is pushed forward as far as possible, and the RETRON length gauge is attached to the guide sleeve. The length is read from the side which is marked "NAIL GAUGE" (Fig. 11).

Operative Technique

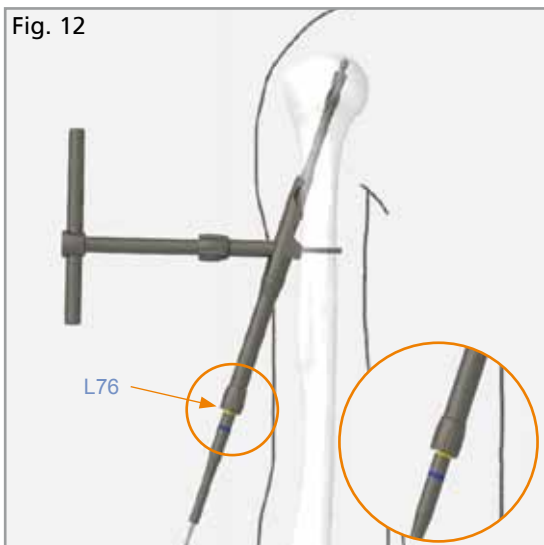

11. Drilling the bone

After removing the guide sleeve, the bone is drilled over the lying wire using the step drill $\varnothing 8 / \varnothing 2.5$ (Cat no. 203-141). Insert the step drill carefully with slight feed and high rotation speed in order to avoid the drill getting stuck.

Note: The required drill depth conforms exclusively to the positioning of the drill in the humeral head, which is to be verified with the help of the image intensifier. The end of the drill defines the future position of the nail. The marking on the drill shaft provides an orientation for the nail length which is to be used (Fig. 12). If the determined length is between the yellow and the blue marking, the short nail L 76 is to be chosen. By means of the diaphysis anchor, the missing length will be compensated in a later step.



12. Removal of the RETRON Positioning Guide

To remove the positioning guide, first remove the step drill and the nail guide wire.

Unscrew the fixation screw by means of the cannulated screw driver (Cat no. 201-146) and remove the positioning guide (Fig. 13).

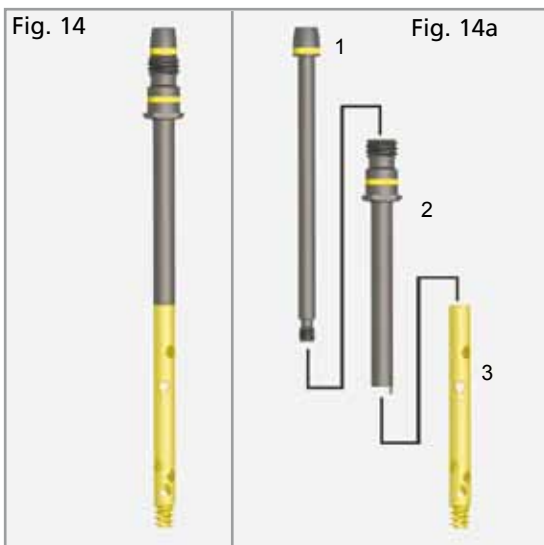

13. Selection and Assembly of the Implant

Selection of the nail in the correct version (right/left) with the previously defined length (selectively L=76 mm or L=86 mm)

Analogically to the defined nail length, preposition the according nail holding screw (Cat no. 204-136 or 204-138) and the suitable nail adaptor (Cat no. 204-135 or 204-137), then assemble as a unit (Fig. 14).

The nail holding screw (1) is guided through the nail adaptor (2) and is screwed together with the nail (3) (Fig. 14 a).

Note: Before insertion of the nail, the chosen implants should be verified by assembling with the targeting device. For this purpose have the targeting device (Cat no. 204-132) and the fastening screw (Cat no. 204-131) ready. Close the target drill holes that are not required (depending on the side R=right or L=left) with Silicone Plugs (Cat no. 204-124). Put the targeting device onto the nail adaptor and tighten the connection of the nail to the nail holding screw by means of the screw driver SW 4, until it is hand-tight. Attach the connecting screw and tighten with the screwdriver SW 4. Introduce the guide sleeve $\varnothing 7 / \varnothing 1.6$ (Cat no. 202-122) into the tissue protection sleeve $\varnothing 9 / \varnothing 7$ (Cat no. 202-121) and affix it using one rotation. Push the sleeves little by little through the open target drill holes in the targeting device. Check the passage through the locking drill holes in the nail by pushing a guide wire $\varnothing 1.6 / L 245$ through.

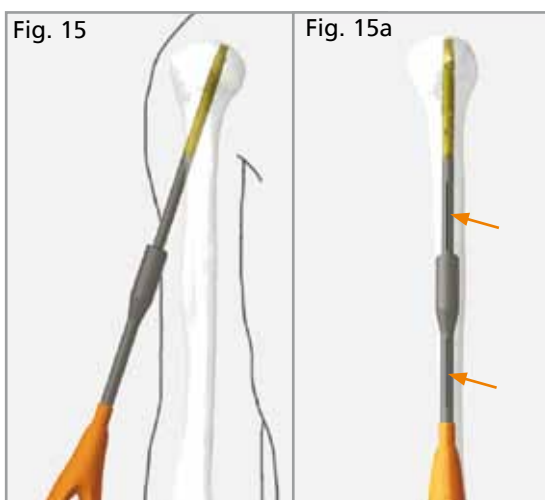

14. Implantation of the Nail

Direct the unit consisting of nail adaptor, nail holding screw and nail (see Fig. 14) to the bone and implant it with the insertion / removal driver (Cat no. 201-103), using light pressure. A feed rate of approx. 2 mm per rotation is achieved. The nail is to be screwed in until the proximal end of the nail is sitting subchondrally. The distal end of the nail should then be positioned 2-5 mm within the lateral cortex (Fig. 15).

The correct position of the nail is to be verified under X-ray control.

For a rough alignment, the lines on the nail adaptor and insertion / removal driver must point in the lateral direction (Fig. 15a).

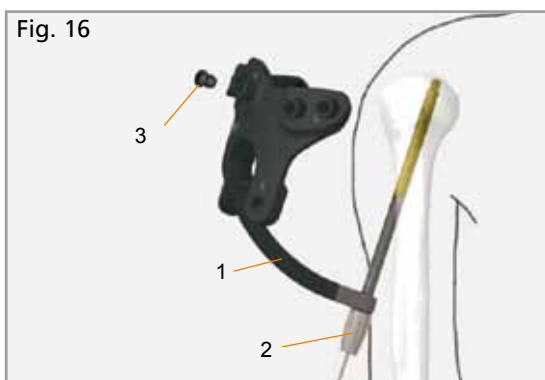

15. Attaching the targeting device

The targeting device (1) (Cat no. 204-132) is seated on the nail adaptor, and the nail holding screw is tightened with the screwdriver SW 4 (Cat no. 201-104). Attach the connecting screw (2) (Cat no. 204-131) and tighten with the screwdriver SW 4 (Fig. 16).

The targeting device is useable on both sides. For a better orientation, the target drill holes that are not required (R=right and L=left respectively) have been closed with silicone plugs (3) (Cat no. 204-124) previously (see paragraph 13).

The targeting device is adjusted so that the screws for the fixation of the minor tubercle and the major tubercle lie on both sides of the biceps tendon.

The correct alignment of the targeting devices is given when the ventral locking screw is led centrally through the minor tubercle. To adjust this position, the lower arm is angled approx. 90°. From a cranial view, the ventral drilling is positioned by a 15-20° angle relative to the angled lower arm; rotated outwards (Fig. 17).



Tip: The screwdriver SW 4, which is inserted into the ventral drilling, may serve as an indicator.

Operative Technique

Fig. 18

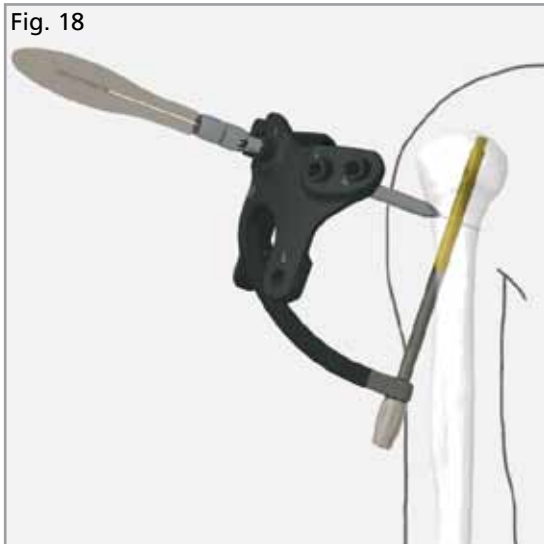
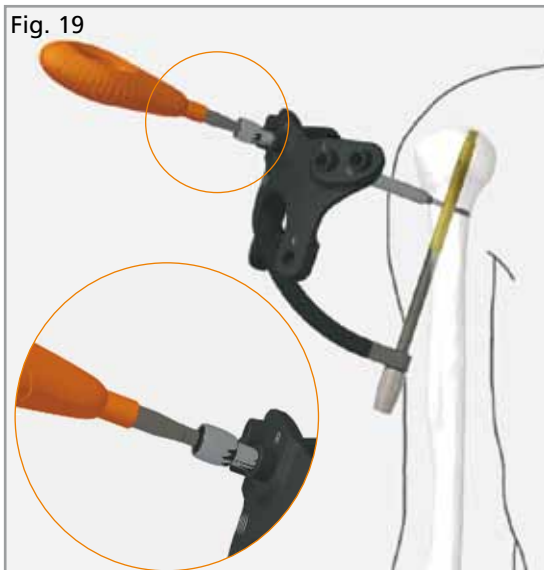

Fig. 19



16. Introduction of the Cannulated Screws

The cannulated screw is initially inserted for the fixation of the minor tubercle. It is followed by the screws for the fixation of the major tubercle and the shaft screw.

Exemplarily, the procedure for the introduction of a shaft screw is described:

The guide sleeve $\text{Ø } 7 / \text{Ø } 1.6$ (Cat no. 202-122) is introduced into the tissue protection sleeve $\text{Ø } 9 / \text{Ø } 7$ (Cat no. 202-121) and is fixed with one rotation. The sleeves are pushed through the target drillings lying outside (R=right and L=left respectively) into the targeting device, and are advanced to the bone following a puncture incision and blunt preparation.

Before setting the guide wires $\text{Ø } 1.6 / \text{L } 245$ (Cat no. 206-108), the correct reduction is to be checked under X-ray control in two planes.

Note: Before introducing the guide wire, make sure that the nail guide wire has been removed.

The screws in the shaft area of the bone are locked bicortically; the screws in the head area are locked monocortically.

For the setting of the screw in the firmer shaft area of the humerus, it is necessary to pre-drill bicortically with the cannulated drill $\text{Ø } 3 / \text{Ø } 1.6$ (Cat no. 203-140) over the lying guide wire. Generally, it is not necessary to pre-drill the cannulated screws that are to be placed in the humeral head area. A monocortical pre-drilling is recommended here if required in case of an especially firm bone substance.

The required screw length is determined with the RETRON length gauge (Cat no. 208-106) by attaching it to the guide sleeve and reading off the scale "SCREW GAUGE" (Fig. 18).

After removing the guide sleeve, the cannulated screw is inserted over the wire by means of the cannulated screw driver T10 (Cat no. 201-146) (Fig. 19).

The ring marking of the screw driver provides an indication for reaching the cortex with the screw head. If the marking reaches the end of the tissue protection sleeve, the screw head lies in front of or at the cortex (Fig. 19). The position of the screw head is to be verified subsequently with the image intensifier.

Fig. 20



Note: If washers (Cat no. 105-130) are to be used, the cannulated screws should be inserted with the washer that was attached beforehand, without tissue protection sleeve. When screwing in the screws ensure that no soft tissue gets between the washer and bone (Fig. 20).

Fig. 21

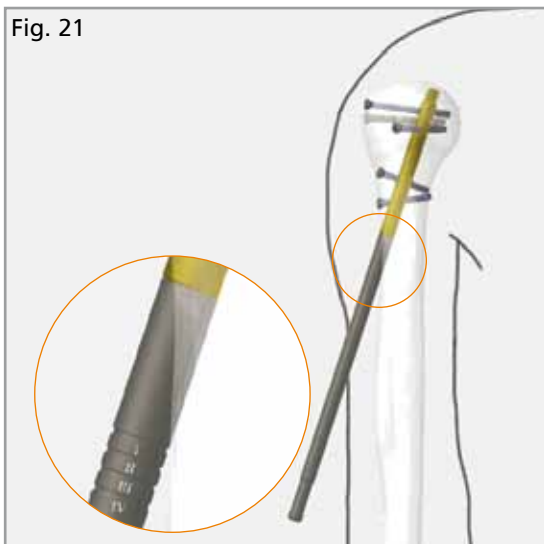

17. Distal anchorage of the implant

Four diaphysis anchors (Cat no. 105-151, 105-152, 105-153, 105-154) with different lengths from 0 mm to 7.5 mm (2.5 mm steps) are available. The required length is determined by means of the sizer (Cat no. 208-107). For this purpose, insert the sizer into the end of the nail and read off the necessary length at the shaft under X-ray control. The ring groove that ends in a-p alignment with the lateral cortex, describes the correct length (Fig. 21).

Operative Technique

Fig. 22

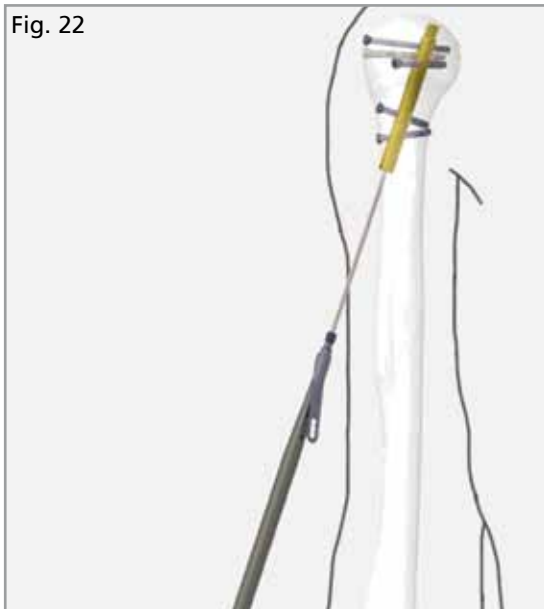

Direct the diaphysis anchor (Cat no. 105-151, 105-152, 105-153, 105-154) together with the connection screw (Cat no. 105-150) to the distal end of the nail, and screw the connecting screw in with the screw driver SW4 so far that the diaphysis anchor lies against the nail, but is not finally tightened. Pay attention to the correct alignment of the diaphysis anchor (Fig. 22).

Tip: If the nail guide wire is inserted again in the distal end of the nail after the removal of the targeting device, the diaphysis anchor can be inserted together with the connection screw, via the wire.

For the fixation of the diaphysis anchor at the bone, a cannulated screw is inserted in the screw hole, which had served the fixation of the positioning guide previously.

The cannulated screw is screwed in with the cannulated screw driver T10 (Cat no. 201-146) (Fig. 23). Finally, the connection screw is ultimately tightened.

Fig. 23



Fig. of the locked RETRON Humeral Nail System (Fig. 23, Fig. 24).

18. Follow-up Care and Management

1-3 weeks immobilisation, with cuff and collar sling or - if necessary - gilchrist sling. Afterwards guided physiotherapy, according to the individual situation. Intra-operative X-ray control, hereafter approx. 10 days post-operatively.

19. Implant removal

In case the implant is distracting, it should be removed after sufficient healing of the fracture. The implant removal is to be carried out in the following order:

Firstly, release the diaphysis anchor. For this purpose, loosen the connection screw (Cat no. 105-150) to the nail by means of screw driver SW 4 (Cat no. 201-104). Then loosen the cannulated screw with the cannulated screw driver T10 (Cat no. 201-146) and take off the diaphysis anchor.

Fig. 24



Determine the length of the implanted nail (L 76 or L 86 mm), and attach the nail adaptor (Cat no. 204-135 or Cat no. 204-137) and the nail holding screw (Cat no. 204-136 or 204-138) to the nail (see paragraph 13 on page 8). Attach the targeting device (Cat no. 204-132) to the nail adaptor and retighten the nail holding screw with the screw driver SW 4 (Cat no. 201-104). Attach the connecting screw (Cat no. 204-131) and tighten it with the screwdriver SW 4.

Tip: The thread in the nail can be found more easily, using the nail guide wire (Cat no. 206-107). For this purpose, introduce the guide wire into the end of the nail, guide the nail adaptor and the nail holding screw over the guide wire into the nail and tighten them by means of screw driver SW 4.

For a better orientation, the target drill holes which are not needed, (R = right and L = left respectively) are closed with silicone plugs (Cat no. 204-124) (Fig. 16).

The guide sleeve $\varnothing 7 / \varnothing 1.6$ (Cat no. 202-122) is introduced into the tissue protection sleeve $\varnothing 9 / \varnothing 7$ (Cat no. 202-121) and is affixed using one rotation. The sleeves are pushed through the outside positioned drillings into the targeting device, and are advanced to the skin.

Following a puncture incision and blunt preparation, the sleeves are advanced to the bone. Remove the guide sleeve and insert the cannulated screw driver T 10 (Cat no. 201-146). Then screw out the cannulated screw. Repeat this procedure for all remaining cannulated screws. Take off the targeting device and attach the RETRON insertion / removal driver (Cat no. 201-103) to the nail adaptor. Screw out the nail.

Alternative procedure to locate the entrance point

The RETRON wire guide may be used as an alternative to the positioning guide.

A5. Affixment of the Wire Guide

Following the reduction and opening (step 4 and 6), guide the correct side version (right or left) of RETRON wire guide (Cat no. 204-139 or 204-140) percutaneous to the cortex.

Attention: Note the position of the axillary nerve.

Attach the wire guide strictly lateral at the dorsal border of the greater tuberosity. Place it in a way that its proximal end lies at the same height where the humeral shaft begins to have a nearly constant diameter (Fig. 25).

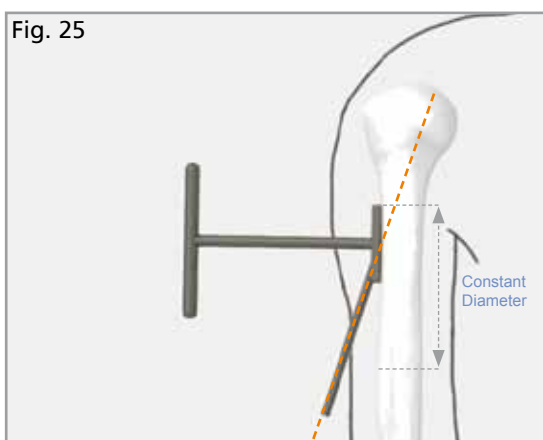

Operative Technique

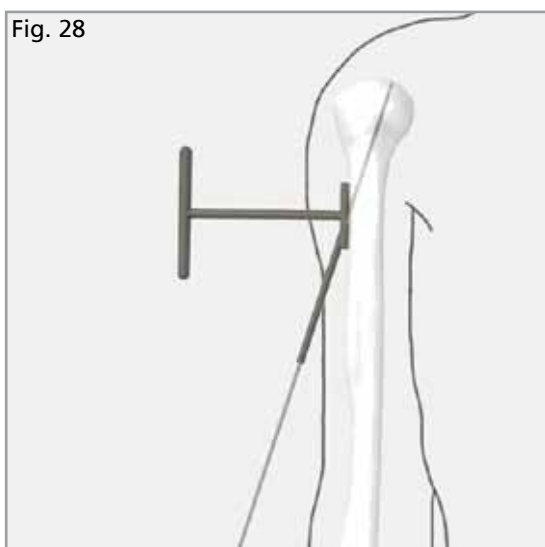
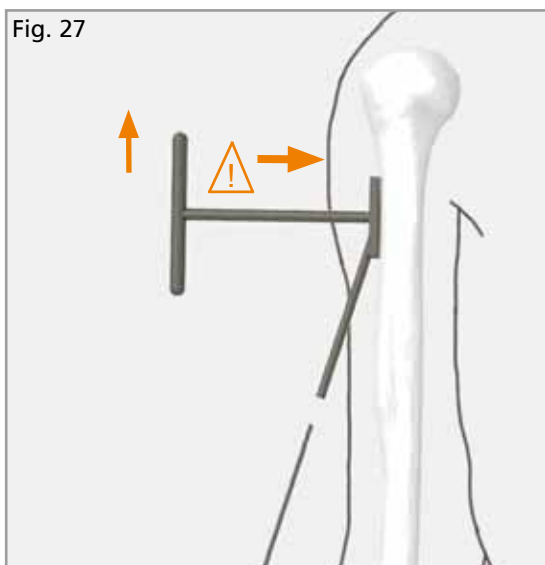

A6. Alignment of the Wire Guide

The correct position of the wire guide is obtained, when the virtual extension of the distal sleeve comes to lie centrally in the humeral head (Fig. 25).

The wire guide exhibits spikes on its underside, which press into the bone and avoid a shifting of the wire guide.

Tip: Additionally the position of the wire guide may be fixed with two guide wires (Cat no. 206-108). The plate of the wire guide has one drilling on the dorsal and one on the ventral end through which the guide wires can be inserted into the bone (Fig. 26).

A7. Bone preparation

The bone is prepared with the spot facer $\varnothing 2.5$ (Cat no. 203-143) to prevent the nail guide wire from deviating. For this purpose set the spot facer with high rotation speed through the sleeve of the wire guide until the stopper is reached.

Note: During opening of the lateral cortex with the spot facer, a light pressing of the proximal part of the wire guide is important to prevent the drilling from straying in the cranial direction.

A8. Insertion of the nail guide wire

The nail guide wire $\varnothing 2.5$ (Cat no. 206-107) is inserted into the humeral head through the sleeve of the wire guide with a drill. The wire lies in the middle third of the humeral head and ends in the subchondral area (Fig. 28).

Depending on the alignment of the image intensifier during X-ray, occasional projection errors may occur. A safety distance between the tip of the nail guide wire and the calotte must be kept in order to avoid drilling through the humeral head.

Note: During the insertion of the nail guide wire, a light pressing of the proximal part of the positioning guide is also recommended to prevent the wire from deviating in the cranial direction.

Fig. 29

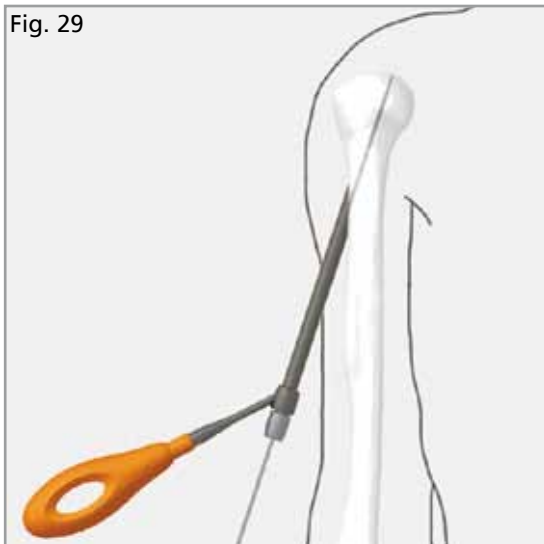

Fig. 30

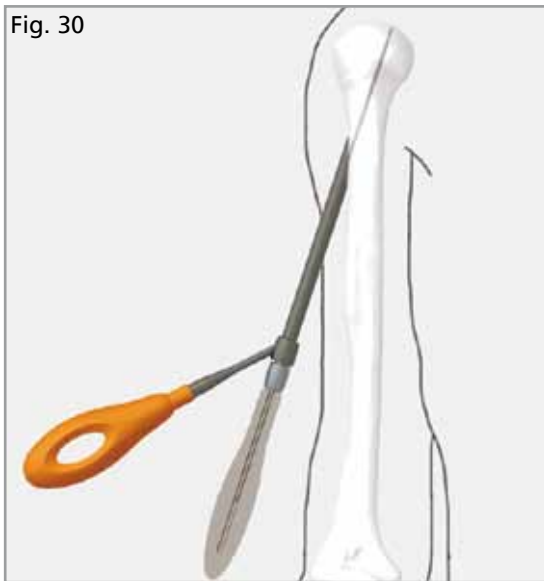
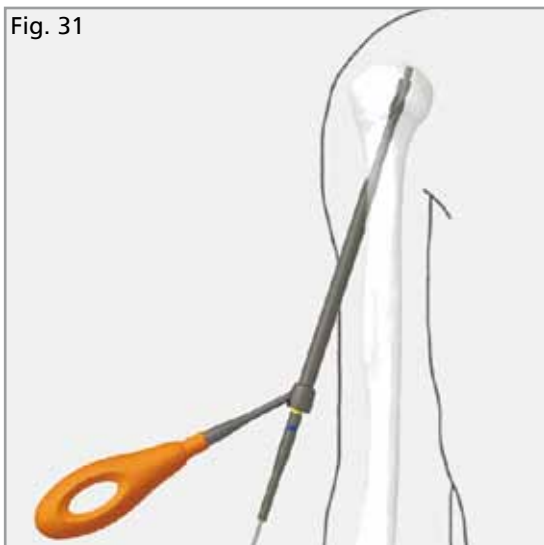

Fig. 31



A9. Attaching of the tissue protection sleeve

Take the wire guide off first, then advance the tissue protection sleeve $\varnothing 8$ (Cat no. 202-128) with inserted guide sleeve $\varnothing 8 / \varnothing 2.5$ (Cat no. 202-129) onto the cortex.

Note: The tip of the tissue protection sleeve is bevelled. Therefore it is stringently necessary to attend to the alignment of the sleeve at the bone (Fig. 29).

A10. Measuring the length

The drill depth is first determined by means of the RETRON length gauge (Cat no. 208-106).

Note: To determine the length correctly, the nail guide wire is placed subchondrally, the guide sleeve has contact to the lateral cortex and the length gauge is laid alongside the guide sleeve. The length is read off at the side which is marked "NAIL GAUGE" (Fig. 30).

A11. Prepare the bone

After removing the guide sleeve, the bone is drilled with the step drill $\varnothing 8 / \varnothing 2.5$ (Cat no. 203-141) over the lying wire. Insert the step drill carefully with slight feed and high rotation speed in order to avoid the drill to get stuck.

The drill depth is read off from the shaft marking on the drill (Fig. 31). Check the drill depth by means of fluoroscopy. Afterwards remove the drill and the nail guide wire.

Note: The required drill depth conforms exclusively to the positioning of the drill in the humeral head, which is to be verified with the help of the image intensifier. The end of the drill defines the future position of the nail. The marking on the drill shaft provides an orientation for the nail length which is to be used (Fig. 31). If the determined length is between the yellow and the blue marking, the short nail L76 is to be chosen. By means of the diaphysis anchor, the missing length will be compensated in a later step.

For the further procedure refer to paragraph 13 on page 8.

RETRON Implants

Humeral Nail



Material: Ti6Al4V (ISO 5832-3)

Size	Side	Cat no.	
		non sterile	sterile
Ø 8, L 76	left	105-141	105-161
Ø 8, L 86	left	105-142	105-162
Ø 8, L 76	right	105-145	105-165
Ø 8, L 86	right	105-146	105-166

Diaphysis Anchor



Material: Ti6Al4V (ISO 5832-3)

Size	Cat no.	
	non sterile	sterile
I (0 mm)	105-151	105-171
II (2.5 mm)	105-152	105-172
III (5.0 mm)	105-153	105-173
IV (7.5 mm)	105-154	105-174

Connection Screw

Material: Ti6Al4V (ISO 5832-3)



Size	Cat no.	
	non sterile	sterile
SW 4, L 16	105-150	105-170

Washer, plain

Material: Ti6Al4V (ISO 5832-3)



Size	Cat no.	
	non sterile	sterile
SW 4, L 16	105-130	105-180

Cannulated Screws



Material: Ti6Al4V (ISO 5832-3)
 Connection: TORX
 Wire Diameter: 1.6 mm
 Material: Ti6Al4V (ISO 5832-3)

Size	Cat no.	
	non sterile	sterile
Ø 4, L 20, T15	101-530	101-560
Ø 4, L 22, T15	101-531	101-561
Ø 4, L 24, T15	101-532	101-562
Ø 4, L 26, T15	101-533	101-563
Ø 4, L 28, T15	101-534	101-564
Ø 4, L 30, T15	101-535	101-565
Ø 4, L 32, T15	101-536	101-566
Ø 4, L 34, T15	101-537	101-567
Ø 4, L 36, T15	101-538	101-568
Ø 4, L 38, T15	101-539	101-569
Ø 4, L 40, T15	101-540	101-570
Ø 4, L 42, T15	101-541	101-571
Ø 4, L 44, T15	101-542	101-572
Ø 4, L 46, T15	101-543	101-573
Ø 4, L 48, T15	101-544	101-574
Ø 4, L 50, T15	101-545	101-575
Ø 4, L 52, T15	101-546	101-576
Ø 4, L 54, T15	101-547	101-577
Ø 4, L 56, T15	101-548	101-578
Ø 4, L 58, T15	101-549	101-579
Ø 4, L 60, T15	101-550	101-580

The Fig.s are schematic and do not correspond with the original dimensions. Subject to technical changes. Revision Feb. 09

RETRON Instruments



204-115 RETRON Positioning Guide



204-116 Attachment for Positioning Guide

204-116A Indicator L76 f. Positioning Guide

204-116B Indicator L86 f. Positioning Guide



202-130 Guide Sleeve Ø 7, Ø 3

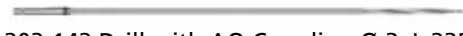

203-142 Drill with AO Coupling Ø 3, L 235



204-142 Fixing Screw for Position Guide Ø 4, L 30



201-148 Screwdriver cannulated T 15



203-139 Spot Facer Ø 8, L 180



202-129 Guide Sleeve Ø 8, Ø 2.5



206-107 Guide Wire Ø 2.5, L 300



208-106 RETRON Length Gauge



203-141 Step Drill Ø 8, Ø 2.5, L 280



202-128 Tissue Protection Sleeve Ø 8



201-103 Insertion / Removal Driver



204-135 Nail Adaptor L 76



204-136 Nail Holding Screw L 76



204-137 Nail Adaptor L 86



204-138 Nail Holding Screw L 86



204-132 Targeting Device 204-131 Fastening Screw M12, SW 4

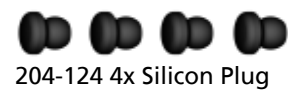

204-124 4x Silicon Plug



201-104 Screwdriver cannulated SW 4



202-121 Tissue Protection Sleeve Ø 9, Ø 7



202-122 Guide Sleeve Ø 7, Ø 1.6



203-140 Drill, cannulated AO Coupling Ø 3, Ø 1.6, L 235

206-108 10x Guide Wire Ø 1.6, L 245



208-107 Sizer



209-122 RETRON Tray

209-123 Implants Case for RETRON Tray

209-124 Silicon insert for Tray



204-139 RETRON Wire Guide right

204-140 RETRON Wire Guide left



203-143 Spot Facer Ø 2.5, L 130

(tantum))

the medical people

tantum AG

Memellandstraße 2

D-24537 Neumünster

Fon +49 43 21 200 59-0

Fax +49 43 21 200 59-19

info@tantum-ag.de

(www.tantum-ag.de